



# Mobile Hybrid Energy System for Modern Drives of Smart Energy Transition

A. Korpela<sup>1</sup> · S. Alanen<sup>1</sup> · L. Hietalahti<sup>1</sup> · M. Kohtala<sup>1</sup> · T. Markkula<sup>1</sup> · K. Virtanen<sup>1</sup> · R. Björn<sup>2</sup>

Received: 20 May 2022 / Accepted: 21 January 2023 / Published online: 1 March 2023  
© The Author(s) 2023

## Abstract

Mainly driven by the climate change, electric power systems are globally going through a transition. In order to cut carbon dioxide emissions and slow down global warming, traditional systems consisting of concentrated, easily controllable and often fossil-based power plants are step-by-step replaced by the ones which are typically distributed, renewable and carbon dioxide free. Often this green and renewable production is weather-dependent and much more difficult to predict than the traditional fossil-based one. In the smart energy transition we are dealing with these critical and topical issues: how to ensure the balance in the power grid, when the controllability of production gets more and more difficult. New solutions, such as flexible loads, demand response and growing role of energy storage, are called for to ensure high quality of electric energy. In all these solutions, more accurate power control is called for. In addition, it is important to realize that such new solutions of modern electric drives always require sophisticated power electronics combined with smart control. To be able to demonstrate these modern electric drives of smart energy transition, a mobile and technically versatile hybrid energy system was designed and built at Tampere University of Applied Sciences. In addition to easy transfer enabled by a trailer solution, the goal of design and construction was in technical diversity. The hybrid energy system presented in this paper has not been tailored to any specific use, but instead, we wanted to be able to demonstrate even such modern electric drives that were not predictable in the design phase of the system. Thus, the technical diversity of the system deserves to be emphasized. In this paper we present the design, the operational principles, smart control properties and some successful demonstrations of energy transition related modern electric drives.

**Keywords** Energy storage · Renewables · Electric vehicles · Power electronics · Isolated operation · Hybrid energy system · Intelligent control

## Introduction

In smart energy transition, carbon dioxide emissions of energy production are decreased in order to decelerate global warming. Consequently, the triumph of wind and solar power goes on, and no sign of abatement can be seen. For example in Finland nuclear power, bioenergy and hydro-power have traditionally comprised strong cornerstones of production, but according to many views, wind power is a strong candidate to stand up as another one during the following decade [1, 2]. In smart energy transition, easily

controllable fossil-based production is replaced mainly with weather-dependent production that cannot inherently be controlled. Consequently, energy transition increases the demand for more accurate power control in order to ensure the balance between production and consumption. The mobile hybrid energy system presented in this paper was built to demonstrate such power control related electric drives in kW scale. We wanted to design a system which is not tailored to any specific use, but instead, can be utilized to demonstrate any modern electric drive of smart energy transition. In addition to technical versatility, this also required easy mobility.

In 2020, the share of renewables of gross final energy consumption in European countries was 22.1% [3]. In Finland the corresponding figure was 43.8%, mainly due to a strong role of bioenergy, but also due to a growing share of wind power [3]. The triumph of renewables will continue,

✉ A. Korpela  
aki.korpela@tuni.fi

<sup>1</sup> Tampere University of Applied Sciences, Tampere, Finland

<sup>2</sup> Tampere Adult Education Centre, Tampere, Finland

and European investments on climate-friendly energy production and energy self-sufficiency will further gain a significant boost due to the latest actions in Ukraine, as European countries aim to decrease their dependence on Russian energy [4].

Due to energy transition, sensitivity of power grids on disturbances is prone to increase. This is mainly caused by the reduction of inertia, which takes place when massive synchronous generators from fossil-based power plants are disconnected from the grid. Inertia offers stability of frequency in electric energy systems, and its reduction increases the sensitivity of frequency in the situations of power imbalance. Consequently, the demand for more accurate power control increases, and new technical solutions are also called for. One promising technical solution is the combination of energy storages and smart control. Another solution is to have a finer time resolution in the electricity markets. This is why the imbalance settlement period in the electricity markets will be decreased from one hour to fifteen minutes in most European countries. In Finland this will take place on the 22<sup>nd</sup> of May 2023 [5]. Our motivation towards technically versatile hybrid energy system originally arose from this entity of power balance and the demand for more accurate power control. Our main objective was to design and to build a system which enables large variety of smart energy transition related demonstrations, in which more precise power control has a key role.

The hybrid energy system presented in this paper has been designed and built in two consecutive projects. The hardware was designed and built in the first project, and the second one concentrated on smart power control. The first project, *Optimized Utilization of Renewable Electrical Energy by Means of Energy Storage*, originated from the growing demand of energy storage in large-scale energy systems [6]. The role of energy storage is topical and growing in many electric drives of smart energy transition, such as peak shaving, charging of electric vehicles and utilization of renewables. To demonstrate and to develop these kinds of modern drives of smart energy transition, a mobile hybrid energy system was designed built in two trailers as a collaboration between Tampere University of Applied Sciences, Tampere Adult Education Centre and SMEs operating in the related fields. In brief, the system consists of 100 kWh energy storage, high-power charging stations for electric vehicles (Type2, CHAdeMO, CCS), and versatile power electronics to enable great variety of modern electric drives. In the second project, *Intelligent Control in Modern Energy Systems*, smart and autonomous controls are designed and implemented for the hybrid energy system. Both projects were funded by the Council of Tampere Region in Finland [7].

The word *hybrid* refers to multiple choices for sources and loads of electric energy. For example, photovoltaic

system, energy storages (battery or ultracapacitor), power grid or some reserve power station may simultaneously serve as energy sources with appropriate power figures. In order to enable simultaneous utilization of electrically different sources, sophisticated power electronics is required for matching. Then, electric energy from multiple sources can be supplied to different loads and drives, to power grid or to energy storages. In the design and construction of the system, investment was all the time in the diversity of modern electric drives of smart energy transition. We wanted to enable even such drives that were not predictable in the design phase.

In general, numerous hybrid energy systems have been built for different targets of use. However, mobile ones enabling versatile electric drives of smart energy transition are less common. Many investigations of hybrid energy systems have been targeted for electric vehicles [8, 9], and mobile charging solutions are more and more common [10–14]. In addition, commercial solutions already exist [15, 16]. Other typical uses for hybrid energy systems are in smart grid solutions [17] or in supporting renewables [18, 19]. The mobile hybrid energy system presented in this paper is not tailored for any specific electric drive. Instead, we had one clear goal, which was to build as technically versatile system as possible to test and to demonstrate different modern electric drives of smart energy transition. The innovation of the built hybrid energy system lies in its mobility combined with the versatile power electronics and smart power control enabling many different modern electric drives by using a single system. The main objective is to enable large variety of real-life demonstrations of energy transition related modern electric drives with a single system.

## Research Gap

Some modern electric drives and their technical requirements are presented in Table 1. As already mentioned in the previous chapter, many such equipment and systems exist that can successfully carry out separate electric drives presented in the table. However, technically more versatile ones being capable to handle more wide-ranging modern electric drives are less common. Our goal and also the research question of this study was to design and to implement such technically versatile system that is able to cover exceptionally wide range of modern electric drives of smart energy transition. Maybe the toughest challenge was to prepare in advance for the modern electric drives of the future. Thus, we tried not to exclude any future demonstration about which we are not yet aware of. That is why the power electronics system was designed as versatile and ductile as possible. As a consequence, with our mobile hybrid energy system we are able to demonstrate all the modern electric drives presented in Table 1. And furthermore, many unrepresented drives of the

**Table 1** Modern electric drives (left column) and their technical requirements (top row)

	IPG	ES	AFE	OGI	PV	mobility	CS for EV
peak shaving	x	x					
supporting grid	x	x	x				
mobile charging of electric vehicles		x				x	x
reserve power		x		x		x	
isolated energy system	(x)	x		x	x		(x)
isolated system with grid connection	x	x	x	x	x		(x)
supporting renewables	x	x	(x)		x		(x)

*IPG* intelligent power control, *ES* energy storage, *AFE* active front end, *OGI* off-grid inverter, *PV* photovoltaic system, *CS for EV* charging station for electric vehicles

future can also be demonstrated due to technical diversity of the system. The table includes many technical terms that will be explained in Chapter 2.

### Experimental

In order to have a great variety of demonstration opportunities for the hybrid energy system, easy mobility was chosen to be its necessary feature. Consequently, we ended up to build the system in two trailers. Power electronics and high-power charging stations for electric vehicles were built in one trailer, while the other one includes the energy storage. If everything was built in a single trailer, its mass would have increased too high from easy mobility point of view. Thus, we ended up in two trailer solution presented in Fig. 1.

#### Power Electronics Trailer

From the hardware point of view, the core of the mobile hybrid energy system lies in its versatile power electronics. The complex is based on the modified version of HESS

(Hybrid Energy Supply System) manufactured by MSc Electronics Ltd [20]. In brief, HESS system includes required power electronics to match electrically different sources, loads and storages of electric energy. In order to clarify the operational principles of the system, its simplified circuit diagram is presented in Fig. 2. The connections and related converters for photovoltaic system (PV), power grid and energy storages (ES) are presented on the left of Fig. 2. The directions of power flow are presented with arrows. As can be seen, the connection of photovoltaic system is naturally unidirectional, but the connections of power grid and energy storage are bidirectional. Consequently, we are able to charge and to discharge the storages, and by means of AFE (active front end) bidirectional flow of power is also enabled between the power grid and the hybrid energy system. The role of AFE is to synchronize the produced voltage with the grid. And as can be seen on the right of Fig. 2, by means of off-grid inverter we are able to offer isolated electric network, where galvanic isolation is provided by isolation transformer. Depart from the figure, the trailer-built system includes two connections for energy storages. As can be seen from Fig. 3, there are two separate energy storage

**Fig. 1** Mobile hybrid energy system built in two trailers. The left trailer includes energy storage system, and the right one encloses power electronics system and high power charging station for electric vehicles



**Fig. 2** Simplified circuit diagram of the HESS system. Power flow control of hybrid energy system is based on the DC voltage level of intermediate DC circuit presented with dotted box in the middle of the figure

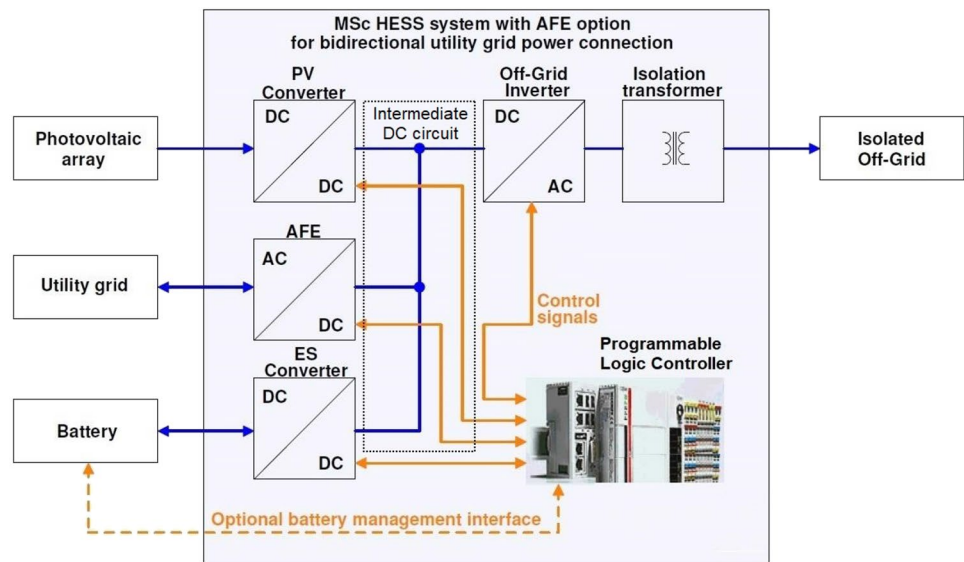

**Fig. 3** Overview to power electronics trailer shows how the main components of Fig. 2 have been installed in the trailer. LCL filters are used to remove harmonics



converters. They were primarily designed for battery systems, but ultracapacitors can be connected also.

As can be seen from Fig. 2, matching of sources, loads and storages is based on the principle of common DC (direct current), since the power connections in the intermediate circuit of Fig. 2 take place in DC. The common DC voltage up to 750 V is determined by the highest voltage given by the converters and AFE. Off-grid inverter transforms DC voltage into symmetrical three-phase AC, which is isolated from the power grid. In practice, our trailer-built HESS (Fig. 3) has many technical modifications compared to the commercial one, but still the operational principle remains unchanged [21].

The charging stations for electric vehicles are also located in the power electronics trailer. They are either supplied from isolated off-grid created by the off-grid inverter, or alternatively they can be directly supplied from the power grid. Two separate charging stations have been installed. The maximum current for EVlink Type2 charging station manufactured by Schneider Ltd is 32 A, and it supplies AC (alternating current) to a vehicle. This results in the maximum charging power of about 20 kW. The other charging station is iES Tower providing both CHAdeMO and CCS. In these cases, energy is supplied to a vehicle in DC. The maximum current and maximum power of iES Tower are 80 A and 55 kW, respectively. As charging stations of electric

vehicles are typically stationary, a practical test of mobile trailer solution is carried out along with the projects.

## Energy Storage Trailer

The other trailer (Fig. 4) includes a self-built energy storage system with the capacity of 100 kWh. LFP (lithium ferrophosphate) battery cells were bought from SIG Energy Technology, but thereafter the system was designed and constructed at Tampere University of Applied Sciences [22]. It consists of altogether 108 cells connected in series. The connection is divided into nine modules, each consisting of 12 cells in series, as presented in Fig. 5. Furthermore, the modules are enclosed in steel boxes for safety reasons. If looked carefully, nine steel boxes can be seen behind the switchboard in Fig. 4. The energy storage system is monitored with the battery management system (BMS) manufactured by Orion [23], and bus interface is used to control the energy storage from the control unit of the hybrid energy system [24].

According to manufacturer, minimum electric values for a single cell are 277 Ah and 3,22 V, which result in the minimum capacity of 892 Wh per cell. As the number of cells is 108, the total minimum capacity is thus 96,3 kWh. However, in practice these minimum values were exceeded in such a way that the total capacity of the built energy storage system is quite precisely 100 kWh. Functional charge window is 10–90%, and the C value determining the maximum power for charging and discharging is 1C. Although the energy storage enables the power of about 100 kW, in practice the power electronics presented in chapter 2.1 limit

the maximum power of the total hybrid energy system to about 50 kW.

The connection between two trailers was implemented with GB/T standard charging cable for electric vehicles manufactured by Phoenix Ltd. This type of charging cable includes altogether nine conducting wires, which was just enough to enable the transfer of all the necessary signals between the trailers. Two of the wires were reserved for the main DC voltage of the battery system (plus and minus), two wires were required for the CAN bus, another two wires were required for auxiliary 24 V voltage (plus and minus), and remaining three wires were reserved for AC connection: phase, neutral and PEN conductors.

## System Control

The hybrid energy system is controlled with programmable logic controller (PLC) by Beckhoff Ltd [25]. Based on measured data and commands given by the user, PLC gives reference values of currents and voltages to converters and charging stations. The main variable affecting the hybrid energy system operation is the DC voltage level of the intermediate circuit presented in Fig. 2. The idea of the DC intermediate circuit is to enable the simultaneous utilization of electrically different sources and loads. As can be seen, PV converter, AFE, ES converter and off-grid inverter are connected via DC intermediate circuit, which has the nominal voltage level of 750 V. Thus, energy from each input of the hybrid energy system is converted into DC with this nominal voltage level. For example, if electric energy is taken from three-phase utility grid having

**Fig. 4** Side-view (left) and rear-view (right) of energy storage trailer



**Fig. 5** LFP cell (left), a mechanically supported module consisting of 12 cells in series (middle), and three modules enclosed in separate steel boxes (right)



25 A main fuses, AFE converts this maximum power ( $3 \cdot 230 \text{ V} \cdot 25 \text{ A} \approx 17.25 \text{ kW}$ ) into DC energy. Resulting DC values of voltage and current are approximately 750 V and 23 A ( $750 \text{ V} \cdot 23 \text{ A} = 17.25 \text{ kW}$ ). If there is no consumption in the isolated off-grid, energy is utilized to charge the battery.

The direction of power flow is controlled with the setpoint DC voltage value of converters and AFE. If we want to charge the battery energy storage, the setpoint voltage of ES converter will be set below the nominal voltage of DC intermediate circuit. And on the contrary, by increasing the setpoint voltage of ES converter above the nominal value we are discharging energy from the battery towards the DC intermediate circuit. The difference between the setpoint voltage of the converter and the nominal voltage of the DC intermediate circuit is directly proportional to the power of charging and discharging: the bigger the difference, the higher the power. This principle of power flow control applies also to PV converter, AFE and off-grid inverter: the power flow is controlled with the setpoint voltage relative to the nominal voltage of the DC intermediate circuit of the hybrid energy system.

The touch screen of the control unit (Fig. 3) provides the user interface for the hybrid energy system. Figure 6 presents the main screen of the user interface, which can be used to monitor the overall status of the system and to adjust several variables. User interface enables easy access to currents, voltages, powers, temperatures and energy storage related parameters, which are important in monitoring and controlling the system. A remote access to the hybrid energy system has also been implemented. Thus, any smart device can be used to remote control the hybrid energy system via mobile network connection.

## Requirements of Smart and Autonomous Controls

In order to implement smart and autonomous controls for the hybrid energy system, we need to be able to control the power flows in the electrical connection point to the power grid. Power flow control requires a continuous measurement of voltages and currents, since active power, which we need to control, can be calculated from the product of voltage and current.

As can be seen from Fig. 7, inside the hybrid energy system we have three system-integrated voltage and current measurements. As these measurements are system-integrated, they are connected all the time, and their values can be directly used to control the system. However, in order to control the power taken from the grid, we need to be able to measure power in client's connection point to the power grid. Thus, the fourth measurement presented in the left of Fig. 7 can be considered as the most important one, since it gives the information about the power taken from the grid. This measurement has to be separately connected case-by-case, when the hybrid energy system is connected to client's network.

In order to carry out reliable power measurements in the client's connection point to the power grid, some details have to be taken into account. First of all, the measurement of current in the connection point is quite simple, since no galvanic contact is required. We ended up to measure three phase currents with Rogowski coils, which are installed around three phase wires. However, quite many details have still to be taken into account in order to ensure reliable current measurement. The problem is that the phase order is not necessarily correct in the client's connection point to the power grid. It is not that uncommon that three phases have changed their positions without changing the right direction

**Fig. 6** User interface of hybrid energy system: active powers of pv system, energy storage and utility grid (left), system status and voltage of DC intermediate circuit presented in Fig. 2 (middle), and active power of isolated off-grid (right)

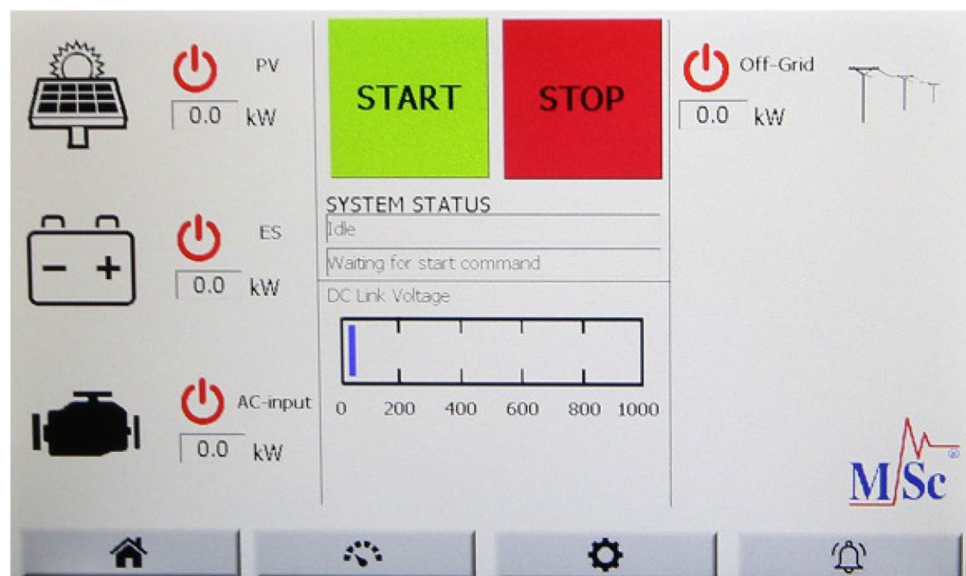

**Fig. 7** Mobile hybrid energy system connected to client's network via 3-phase plug

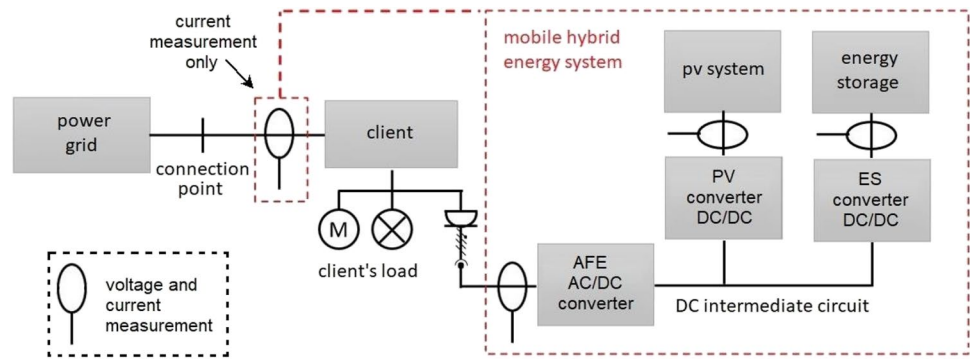

of rotation. Only the right direction of rotation is significant for the operation of electric devices inside the client's network, but from the power measurement point of view, also the right order of phases is crucial. In addition, we need to be able to check that the direction of current probes is correct. It is always possible that a person performing the measurement accidentally installs the probes incorrectly. By implementing appropriate software conditions and checks in the power measurement module, these details of current measurement in the client's connection point to the power grid were finally successfully solved.

The measurement of voltage in the connection point of Fig. 7 is more difficult, since it would have required a galvanic contact between the voltage sensors and the phase wires. Regardless, the installation of voltage sensors has to be easy and safe. These requirements didn't seem possible to fulfil, which drove us to search for another solution. As already mentioned, the hybrid energy system has an integrated voltage measurement in its own connection point to a client's network via a 3-phase plug. This can be seen on the left side of AFE in Fig. 7. However, in this connection point the values of voltages may differ so much from the ones measured in the connection point to the power grid that they cannot be directly used in the power measurements. The difference is due to the client's own network, which may cause enough voltage drop to make the power measurement unreliable.

Thus, we have a voltage measurement, but its values cannot be directly used to measure power in the connection point to the power grid. Figure 8 clarifies the situation by presenting a one-phase equivalent circuit of the connection. By means of the measurement presented in the left hand of Fig. 7 ("current measurement only"), we already know the total phase current  $I_p$  taken from the power grid, but the unknown voltage  $U_{cl}$  is the one that we need for the grid power measurement. In addition, the voltage  $U_{HES}$  is the one that we already have from the system-integrated voltage measurement (left to AFE) in Fig. 7. Because client's own network causes the voltage drop  $U_{Rh}$ ,  $U_{HES}$  differs from  $U_{cl}$ . Luckily the hybrid energy system includes the ability to perform a loading test for client's

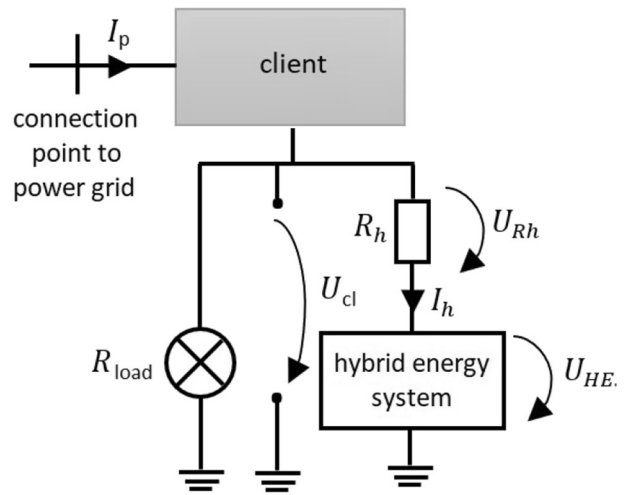

**Fig. 8** One phase equivalent circuit of the connection illustrating the means to deduce the required voltage  $U_{cl}$

network, which enables the measurement of the network resistance  $R_h$ . Then,  $U_{cl}$  can be deduced from

$$U_{cl} = U_{Rh} + U_{HES} = R_h I_h + U_{HES}. \tag{1}$$

Thus, reliable value of the voltage in the power grid connection point of Fig. 7 can be deduced from the integrated voltage measurement of the hybrid energy system. Avoidance of slightly risky voltage measurement requiring galvanic contact with high voltage conductors can be considered as an important safety precaution from the hybrid energy system operation point of view. Consequently, the left side measurement presented in Fig. 7 has "current measurement only", as written in the figure.

## Results and Discussion

The design and especially the building phase of the mobile hybrid energy system have not been straightforward. Many different problems were confronted, but due to diligent

testing and many iterations, reliable and high level of system operation was finally reached. In this chapter some demonstrations and future plans are explained.

### Smart Control of Power Flow

When reliable power measurement module was integrated to the hybrid energy system, we possessed all the required hardware to carry out smart power flow controls. As already mentioned, charging and discharging modes of the energy storage are simply controlled by the setpoint voltage of the energy storage DC/DC converter. By increasing the setpoint voltage from the nominal one we accelerate the discharging of the storage. And on the contrary, by decreasing the setpoint voltage from the nominal one we accelerate the charging of the storage. Smart power controls were carried out by programming the PLC which controls the hybrid energy system (Fig. 2).

The smart control of power flow was implemented with so called *power tube model*. By power tube we mean that the goal is to keep the power taken from the grid between certain limits. By means of battery energy storage we aim to carry out for example peak shaving, which means that client's power demand exceeding the upper limit of the power tube will be taken from the storage. And in order to constantly maintain the energy storage usability and the peak shaving ability, energy storage also needs to be charged during appropriate moments. Consequently, when client's power demand drops below the lower limit of the power tube, storage will be charged.

When implementing smart power control, it has to be noted that client's power demand probably depends greatly on the season of year. For example in Finland, it is quite normal that the electric power demand in typical household is during winter time 3–fivefold compared to summer time,

since heating usually consumes the vast majority of electric energy. This naturally causes challenges to the power tube model. If the same lower and upper limits are applied for the whole year, energy storage will not certainly be operated optimally. Thus, when the hybrid energy system is connected to client's network, we need to be able to adjust the location of power tube depending on the seasonal changes in power demand.

In order to optimize the usability of the energy storage in varying weather conditions, we ended up to adjust the location of the power tube based on two-week ( $P_{ave2w}$ ) and one day ( $P_{ave24h}$ ) average power demands of the client. More precisely, the center of the power tube was chosen to equal  $P_{ave2w}$ , and difference between  $P_{ave2w}$  and the real power demand was adjusted by means of yesterday's value for  $P_{ave24h}$ , which acted as an integrator-like term in the control process. In order to have  $P_{ave2w}$  for each two-week period of the year, we need client's energy consumption profile as a source information. And after 24 h of operation, we are able to adjust the location of the power tube with the measured value of  $P_{ave24h}$ . Thus, the hybrid energy system has a continuous measurement of client's power demand, from which we automatically get the new value of  $P_{ave24h}$  for the next day. This way the location of the power tube is automatically adjusted according to changes in seasonal weather conditions. The lower and upper limit of the power tube were chosen to be 80% and 120% of the center value, respectively.

Before implementing power tube to the real hybrid energy system, its operation was simulated in by means on digital twin in Matlab/Simulink environment. Figure 9 presents the simulated results for one year period. The aim of the simulation was to enable client's peak shaving ability for the whole year by smoothening the grid power to the vicinity of  $P_{ave2w}$ . In other words, the goal was to maintain typical seasonal average power but eliminate high power peaks that stress the

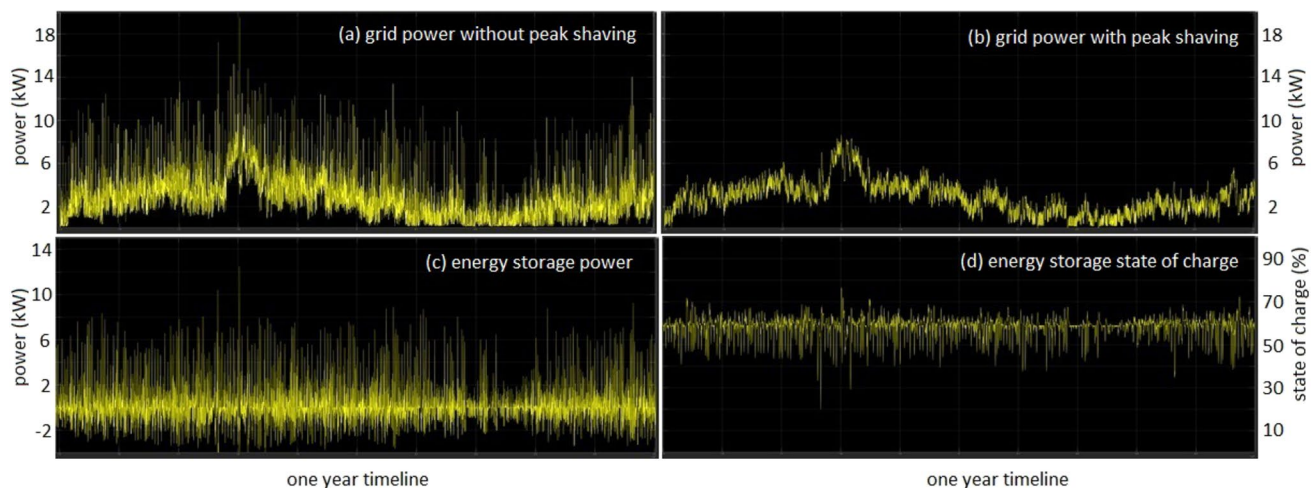

Fig. 9 Power control example with power tube model for one year timeline



grid and possibly increase demand charges. As can be seen from Fig. 9(a), power peaks approaching 20 kW exist without peak shaving. But when appropriate peak shaving was carried out with the 100 kWh energy storage of the hybrid energy system in Fig. 9(b), peaks are shaved below 10 kW even in winter time. As can be seen from the energy storage power in Fig. 9(c), the principle of charging the storage when client's power demand drops below  $0.8 \cdot P_{\text{ave}24\text{h}}$  works quite fine. This can be seen from Fig. 9(d), where the energy storage remains usable all year round. Thus, its usability is 100%. However, it has to be emphasized that 100% usability is due to implementation of  $P_{\text{ave}24\text{h}}$  as the integrator in the control process. Originally we started the power tube model by using constant value for its location. Not surprisingly, it resulted in poor usability of the energy storage. Next, we tried to use only two-week average power as the center of the power tube. As a result the usability increased significantly, but still occasional power peaks were taken from the grid as the state of charge drifted too low. Only after using daily average power as the integrator in the control process we reached the energy storage usability of 100%.

To increase the clarity of power behaviour, Fig. 10 repeats the results of Fig. 9 with the timeline of one week. Some more precise remarks can now be drawn. For example, it can be seen that the shapes of grid power without peak shaving (a) and the energy storage power (c) remind each other significantly. This wasn't clearly visible in Fig. 9. The similarity of shapes is naturally due to peak shaving, since the peaks exceeding  $P_{\text{ave}2\text{w}}$  are taken from the storage. Furthermore, with peak shaving the

grid power can be seen to vary according to daily variations in  $P_{\text{ave}24\text{h}}$  (Fig. 10(b)). When high peaks take place, they increase the value of  $P_{\text{ave}24\text{h}}$ , which raises the center of the power tube for the following day. This is why the shaved peaks increase the grid power with peak shaving in Fig. 10(b) with one day delay.

Same kind of peak shaving results with related equipment can also be found elsewhere, but typically the systems are quite much tailored to a certain use [26]. Tailoring naturally decreases the cost of the system, but at the same time it heavily reduces the number of potential applications. In the mobile hybrid energy system presented in this paper the main goal was to enable a large variety of modern electric drives enabled by the technical versatility of the power electronics system.

The presented power control was implemented to the real hybrid energy system by means of the flowchart presented in Fig. 11. First some input values are given (phase 1), and then the program checks that everything is ok in the power measurement module (phase 2). Next the initial location of the power tube is deduced from the inputs (phase 3), after which the system checks that there are no technical limitations for power tube operation (phase 4). One example of such a limitation is too low state of charge of energy storage. After this the actual power control is carried out by giving appropriate set point DC voltages for the converters and inverters presented in Fig. 2 (phase 5). By controlling these voltages we are directly able to control the magnitudes and directions of power flows in the system. The effects of the power control are then measured in client's connection

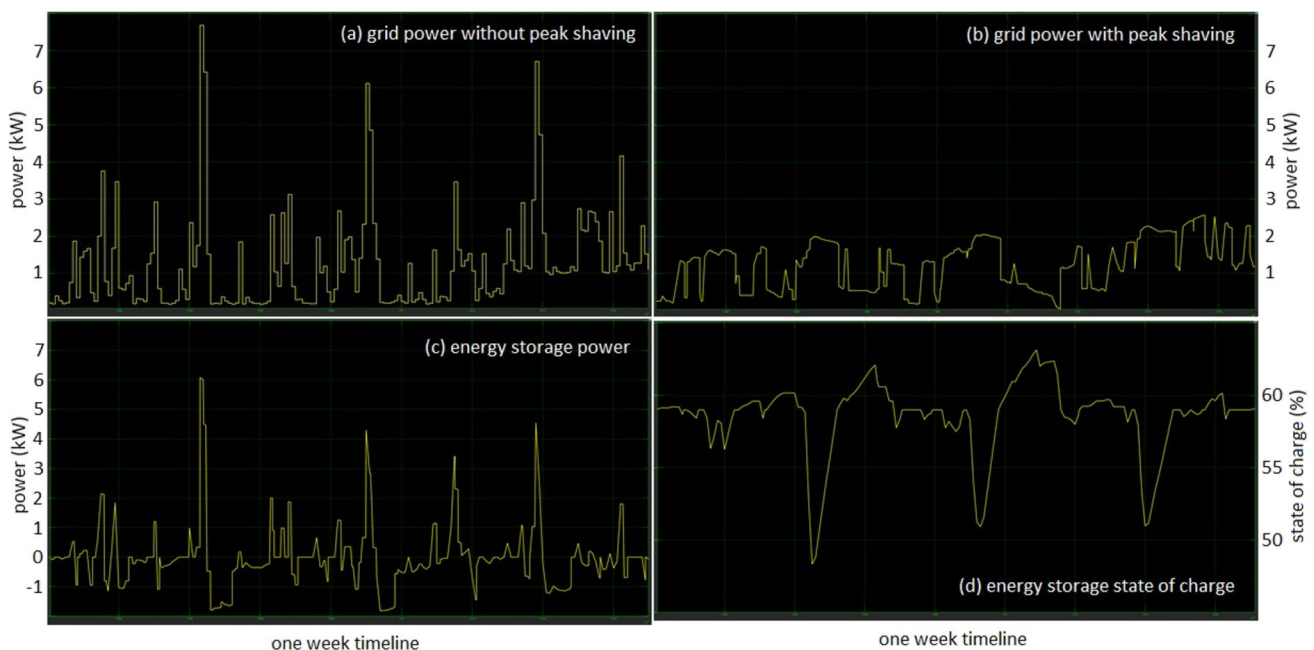

Fig. 10 Power control example with power tube model for one week timeline

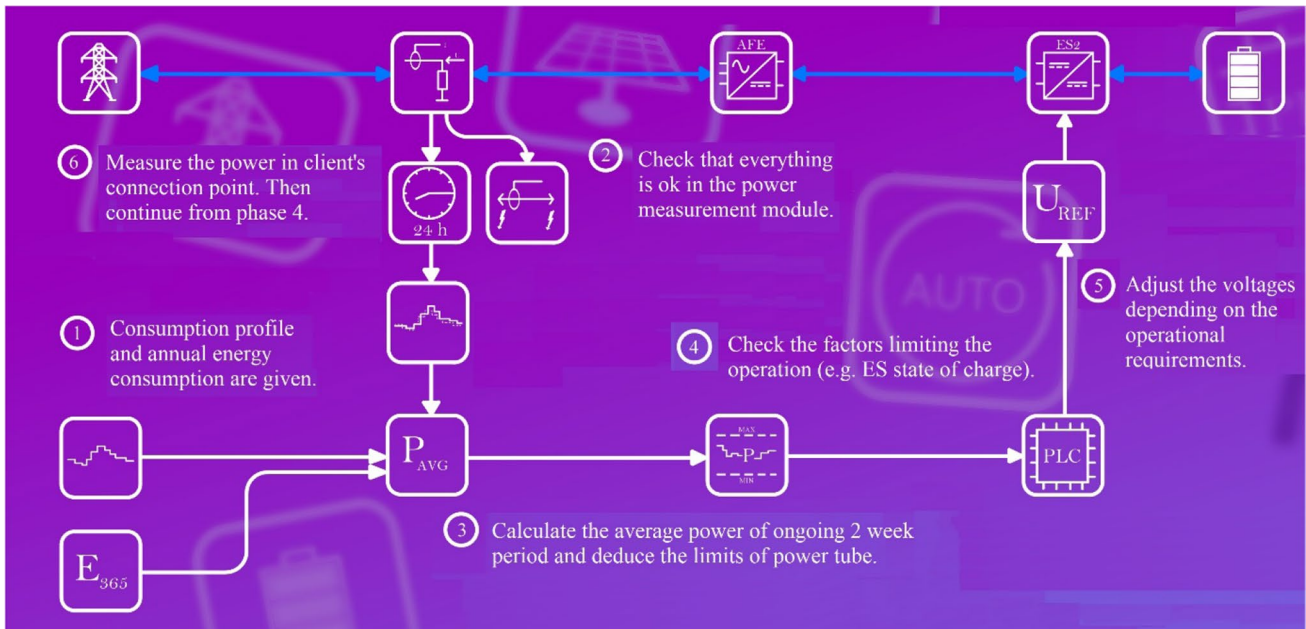

Fig. 11 Flow chart of power control implementation on hybrid energy system

point (phase 6), after which the procedure returns to check the technical limitations in phase 4.

**Public Demonstrations**

After reaching the high level of reliable operation, and after implementing the simulated power tube into the real hybrid energy system, we were ready for public demonstrations. Figure 12 presents two such demonstrations. In the left one the hybrid energy system was utilized to charge electric vehicles in a conference organized at Tampere city center during autumn 2020. In this demonstration the power taken

from the grid was limited to 20 kW, and auxiliary power was taken from the energy storage. In a typical setup presented in the figure an electric vehicle was charged with the total power of 50 kW consisting of 30 kW from the storage and 20 kW from the grid. More generally, as the triumph of e-mobility seems inevitable, boosting of charging power by means of energy storage will probably have large commercial demand already in the near future [27].

Another real life demonstration was to support the weak power grid in an agricultural location having consumption equipment of high nominal power values. Such situations are quite typical in Finland, where power grid is not the

Fig. 12 Two public demonstrations of the hybrid energy system: 1) boosting the charging power of electric vehicles by means of energy storage (left), and 2) supporting weak power grid by means of peak shaving (right)



strongest in a countryside, where large farms are usually located. This target of demonstration suffered from electric energy quality issues. For example, when high-power devices of a dryer building were turned on, occasionally one of three phases was lost due to overloading. As can be seen from the right photo in Fig. 12, significant nominal power (about 50 kW) of solar electricity was already installed to support the power grid. The hybrid energy system was utilized in this location for one week, and by means of peak shaving feature presented in chapter 3.1 all the quality issues of electric energy were solved. By means of the power control provided by the power tube model and the energy storage we were able to avoid occasional overloading of the power grid, which was the main reason behind the power quality issues. It seems highly probable that such grid-supporting drives of energy storage will become more common in the near future [28].

In addition, the hybrid energy system served as a green reserve power in Finland's biggest Scout camp possessing about 2000 participants [29]. By using the hybrid energy system as a reserve power, an arsenal of fossil fuel based electric generators was totally avoided. Consequently, the mobile hybrid energy system is able to provide green reserve power for off-grid solutions. Currently we have several new demonstrations under consideration, and maybe one of the most interesting ones at the moment is V2G (vehicle to grid). The versatile power electronics of the hybrid energy system provides nice environment to test different electric drives for discharging energy from an electric vehicle to external usage. To make it simple, in this case the battery in Fig. 2 will be replaced with an electric vehicle enabling V2G option.

According to already implemented demonstrations, the main goal of the projects has been successfully achieved: the built mobile hybrid energy system offers technical versatility to carry out a large variety of energy transition related modern electric drives that enhance the utilization of renewables and energy storage. In this paper only the demonstrations to shave off peaks, to boost the charging power of electric vehicles, to support weak power grid and to offer green reserve power for off-grid solutions were presented. As technical versatility was chosen to be the main goal in the design of the hybrid energy system, we have been able to carry out quite different demonstrations of energy transition related modern electric drives with a single hybrid energy system. Furthermore, there are still many demonstrations yet to come, since the utilization of energy storage is becoming more and more common in different situations, which all require at least some power electronics and smart control. In our mobile hybrid energy system the goal was to achieve such technical versatility that modern electric drives of future can also be demonstrated, although we are not yet clearly aware of their technical details.

## Discussion

Energy transition gives rise to increasing demand of more accurate power control in electric energy systems. In addition, during the year 2022 this demand has been strongly boosted by the military actions in Ukraine and the following energy crisis in Europe. For example, recent actions in the EU level suggest to cut peak electricity use by 5% [30]. In order to carry out such actions, more comprehensive power control in electric energy systems is called for.

Some examples of modern electric drives requiring power control are balancing the grid, peak shaving, demand response in its various forms, and for example auxiliary charging power for electric vehicles. These all represent quite new commercial applications for power control and energy storage. However, from innovation point of view there is actually nothing really technically new in the required equipment. Hardware for the implementation of power control is commercial, and several options to implement the control exist. On the other hand, innovations can be found for example from the concepts of control implementation. From the economical point of view it is clear that in order to minimize the expenses, power control system and the required hardware will need to be tailored for a specific use. As ongoing energy crisis has quickly increased the demand for power control, many commercial solutions for power control are about to reach the market. But in order to maximize the commercial benefits, these solutions are always tailored. Otherwise they would include unnecessary technical equipment which increases the price. In our case the goal was totally different. We didn't want to tailor anything, but instead, we wanted to design and build as technically versatile hybrid energy system as possible. We wanted to have a system that enables the demonstration of a large variety of energy transition related modern electric drives. In addition to technical advancement, we suggest that also mobility is one key property in the demonstrations of modern electric drives. If our hybrid energy system had been built as a stationary solution, its usability in different demonstrations would have declined drastically. It is clear that some commercial applications require stationary solutions, but from research and development point of view, mobility opens many interesting opportunities that lack from stationary solutions. To summarize, merits of the hybrid energy system presented in this paper are in its technical versatility and mobility, which enable a great variety of demonstrations dealing with energy transition related modern electric drives.

In the beginning of 2022, economic benefit of power control and energy storage in different applications was still a bit unclear. A simple example can be taken from

the small-scale photovoltaics installed in residential buildings. Utilization of self-produced energy would be much more effective with integrated storage, but quite high costs decrease the rationality of investment at least in Finland, where the price of electric energy has been quite low in international comparison. However, ongoing energy crisis in Europe has changed the situation drastically. Now the time-to-time varying price of electric energy can be manifold compared to 2021. Consequently, regular people have become much more aware and interested about the importance of reasonably priced energy and the reliability of supply. If energy crisis ends some day, we will still have growing amount of weather dependent production in electric energy systems, which increases the variation of price with time. From these perspectives it seems quite inevitable that roles of power control and energy storage will become more and more significant as energy transition proceeds with the revolution of renewable technologies.

## Conclusions

This paper presented the mobile hybrid energy system that was designed and constructed at Tampere University of Applied Sciences as a collaboration between academics and SMEs. The main objective was the ability to demonstrate a great variety of smart energy transition related modern electric drives with a single system. Consequently, easy mobility, technical diversity and accurate power control were the key properties in the system design and implementation. The role of sophisticated power electronics is essential, since electrically different sources, loads and storages of electric energy have to be matched. Other main components of the hybrid energy system are 100 kWh battery energy storage and high-power charging station for electric vehicles.

In order to have intelligent and autonomous control for the hybrid energy system in different applications, so called power tube model was designed and implemented. With the power tube model we are able to control power flows in client's electrical connection point to the power grid. This is important since more accurate power control is a general requirement for modern electric drives. As a result, we are for example able to shave peaks, to boost the charging of electric vehicles, to support weak power grids, or to enable full utilization of hour-based time dependent price of electricity. These are the demonstrations of modern electric drives that have already been carried out, and their successful implementation underlines the technical diversity of the hybrid energy system presented in this paper.

The main results of this paper are the exceptional technical versatility of the built mobile hybrid energy system, successfully implemented smart power control, and successful implementation of energy transition related demonstrations.

Although the system design and implementation have been successful, the hybrid energy system also has its limitations. The biggest of them comes from the maximum power, which is due to power electronics limited to about 50 kW. Thus, our system can only be used in kW scale demonstrations. Another limitation is related to the ability to supply fault current. In fault situations of isolated networks, the supply system has to be able to feed high enough short circuit current to blow all the fuses. In some situations the fault current ability of our hybrid energy system may remain insufficient, which is why we need to consider each demonstration case-by-case.

**Funding** Open access funding provided by Tampere University including Tampere University Hospital, Tampere University of Applied Sciences (TUNI).

**Data Availability** The datasets generated during and/or analysed during the current study are available from the corresponding author on reasonable request.

## Declarations

**Conflict of Interest** On behalf of all authors, the corresponding author states that there is no conflict of interest.

**Open Access** This article is licensed under a Creative Commons Attribution 4.0 International License, which permits use, sharing, adaptation, distribution and reproduction in any medium or format, as long as you give appropriate credit to the original author(s) and the source, provide a link to the Creative Commons licence, and indicate if changes were made. The images or other third party material in this article are included in the article's Creative Commons licence, unless indicated otherwise in a credit line to the material. If material is not included in the article's Creative Commons licence and your intended use is not permitted by statutory regulation or exceeds the permitted use, you will need to obtain permission directly from the copyright holder. To view a copy of this licence, visit <http://creativecommons.org/licenses/by/4.0/>.

## References

1. Koistinen A (2019) Finland doesn't fully understand the superior price of wind power. YLE News. 5th of November. <https://yle.fi/uutiset/3-11045496>. Accessed 12 Oct 2022
2. Sitra (2021) The Finnish innovation fund: Enabling cost-efficient electrification in Finland. Sitra Studies 194
3. Eurostat (2022) Renewable energy statistics: Share of renewable energy more than doubled between 2004 and 2020. <https://ec.europa.eu/eurostat/statistics-explained/>. Accessed 12 Oct 2022
4. Kirby P (2022) Why has Russia invaded Ukraine and what does Putin want? BBC News, 10th of March. <https://www.bbc.com/news/world-europe-56720589>. Accessed 12 Oct 2022
5. Copenhagen Economics: Finer time resolution in Nordic power markets: A cost benefit analysis. CE Publications 2017. <https://copenhageneconomics.com/publications/>. Accessed 12 Oct 2022
6. Korpela A (2018) Suuren kokoluokan energiavarastoteknologioiden teknis-taloudelliset näkymät. TAMK Publications, Series B, Reports 113
7. Pirkanmaan Liitto, The Council of Tampere Region, Kelloportinkatu 1 B, P.O. Box 1002, 33101 Tampere, Finland. [www.pirkanmaa.fi/en](http://www.pirkanmaa.fi/en). Accessed 12 Oct 2022

8. Cao J, Emadi A (2012) A new battery/UltraCapacitor hybrid energy storage system for electric, hybrid, and plug-in hybrid electric vehicles. *IEEE Trans Power Electron* 27(1)
9. Geetha A, Subramani C (2017) Comprehensive review on energy management strategies of hybrid energy storage system for electric vehicles. *Int J Energy Res* 41:1817–1834
10. Atmaja TD (2015) Energy storage system using battery and ultra-capacitor on mobile charging station for electric vehicle. *Energy Proc* 68:429–437
11. Huang S, et al (2015) Design of a mobile charging service for electric vehicles in an urban environment. *IEEE Trans Intell Transp Syst* 16(2)
12. Sandoval JM et al (2013) Batteries-supercapacitors storage systems for a mobile hybrid renewable energy system. *IEEE Electrical Power & Energy Conferenc (EPEC)*
13. Weyers C, Bocklisch T (2018) Simulation-based investigation of energy management concepts for fuel cell - battery - hybrid energy storage systems in mobile applications. *Energy Proc* 155
14. Zhou B., et al. (2018) Multiobjective generation portfolio of hybrid energy generating station for mobile emergency power supplies. *IEEE Trans Smart Grid* 9(6)
15. Kane M (2020) Volkswagen delivered 12 mobile charging stations in Wolfsburg. *InsideEVs*. <https://insideevs.com/news/394881/volkswagen-mobile-charging-stations-wolfsburg/>. Accessed 12 Oct 2022
16. Nio Power, Shanghai, China. <https://www.nio.com/nio-power>. Accessed 12 Oct 2022
17. Hajiaghasia S, Salemnia A, Hamzehb M (2019) Hybrid energy storage system for microgrids applications: A review. *J Energy Storage* 21:543–570
18. Maclay JD, Brouwer J, Samuelsen GS (2007) Dynamic modeling of hybrid energy storage systems coupled to photovoltaic generation in residential applications. *J Power Sour* 163:916–925
19. Nema P, Nema RK, Rangnekara S (2009) A current and future state of art development of hybrid energy system using wind and PV-solar: A review. *Renew Sustain Energy Rev* 13
20. MSc Electronics Ltd, Alasniitynkatu 30, FI-33560 Tampere, Finland. [www.msc.eu](http://www.msc.eu). Accessed 12 Oct 2022
21. Markkula T (2021) Energy storage solutions: Hybrid energy system implementation. BSc Thesis, Tampere University of Applied Sciences. <https://urn.fi/URN:NBN:fi:amk-2021110419275>. Accessed 12 Oct 2022
22. SIG Energy Technology, Tour CIT, 3 rue de l'arrivée, 75015 Paris, France. [www.sig-innotech.com/en](http://www.sig-innotech.com/en). Accessed 12 Oct 2022
23. Orion BMS, Ewert Energy Systems Inc, 161 East St. Charles Rd. Carol Stream, IL 60188, USA. [www.orionbms.com](http://www.orionbms.com). Accessed 12 Oct 2022
24. Alanen S (2020) Implementation of an energy storage control system. BSc Thesis, Tampere University of Applied Sciences. <http://urn.fi/URN:NBN:fi:amk-202003103233>. Accessed 12 Oct 2022
25. Beckhoff Automation LLC, 13130 Dakota Avenue, Savage 55378-MN, United States. [www.beckhoff.com](http://www.beckhoff.com). Accessed 12 Oct 2022
26. Chua KH, Lim YS, Morris S (2016) Energy storage system for peak shaving. *Int J Energy Sect Manag* 10(1):3–18
27. Yao L, Damiran Z, Lim WH (2017) Optimal charging and discharging scheduling for electric vehicles in a parking station with photovoltaic system and energy storage system. *Energies* 10:550
28. Ryan DJ et al (2021) Grid-supporting battery energy storage systems in Islanded microgrids: A data-driven control approach. *IEEE Trans Sustain Energy* 12(2):834–846
29. Scouts of Finland, Töölönkatu 55, FI-00250 Helsinki, Finland. <https://scouts.fi>. Accessed 12 Oct 2022
30. Jackson P (2022) Ukraine war: EU moves to cut peak electricity use by 5%. *BBC News*, 14th of September. <https://www.bbc.com/news/world-europe-62899940>. Accessed 12 Oct 2022

**Publisher's Note** Springer Nature remains neutral with regard to jurisdictional claims in published maps and institutional affiliations.